



SMART TECH
by earth & marver

User Manual

Alexa TUTORIAL Google Home TUTORIAL

The product can only be paired on 2.4G WIFI only
Please set the WIFI account name & password using alphanumeric only

1

1-Installation

Install by removing the front panel of your switch with a screwdriver, as shown in the diagram below.

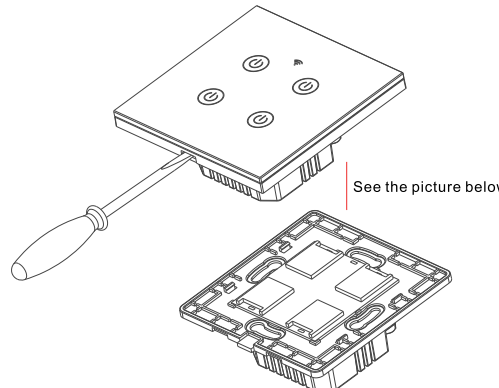

See the picture below

2

2a - Without neutral wire version
(Neutral wire is not required on the switch)
following the diagram below.

- 1 Neutral wire
- 2 Live wire
- 3 Smart switch
- 4 Capacitor connected to L1 & Neutral wire
- 5 6 7 8 Lighting between L1, L2, L3, L4 and Neutral wire.

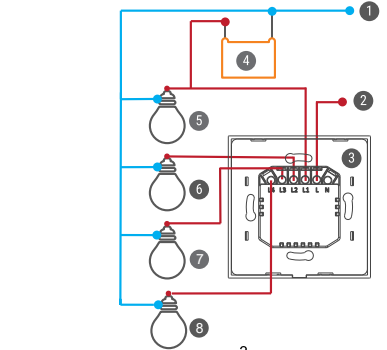

3

2b- With neutral wire version
(Neutral wire is required on the switch)
following the diagram below.

- 1 Neutral wire
- 2 Live wire
- 3 Smart switch
- 4 5 6 7 Lighting between L1, L2, L3, L4 and Neutral wire.

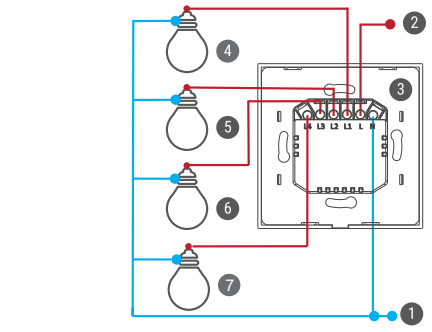

4

3- Installation

- Ensure switching off the circuit breaker.
- Remove the smart switch cover plate.
- Insert the wire into screw terminal on the switch.
- Tuck the wires into the electrical box, then mount the switch to the box with its two mounting screws.
- Reinstall the switch cover plate.
- Restore power to the circuit by switching on the circuit breaker.
- LED Light will be flashing, indicating into pairing mode.

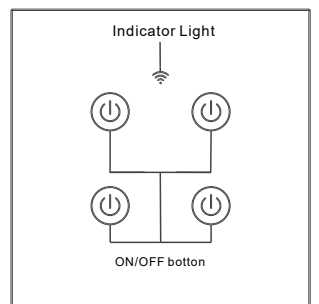



5

4- Indicator Light status

- The WIFI indicator light went off - The smart switch is connected successfully with the mobile APP
- The WIFI indicator blinking slowly - The smart switch is not connected to the network
- The WIFI indicator light flashes continuously & quickly - the smart switch is currently on the status of matching with the mobile APP
- The WIFI indicator light flashes once every 3 seconds - The smart switch is in AP pairing mode.

To reset press and hold any button for 12 seconds.

Smart Life APP Tuya Smart APP

IOS & Android System

6

5- APP Registration

Scan QR code to install Smart life or Tuya APP
Register your device.
Enter your contact number or email address and select the country option.
Obtain and enter the verification code.
Set password.

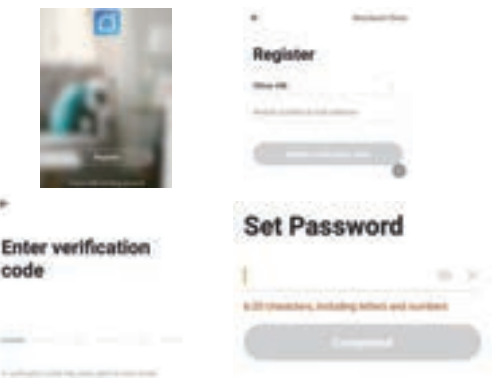

7

Create family.
Enter the family name and select the room.
Family created successfully.

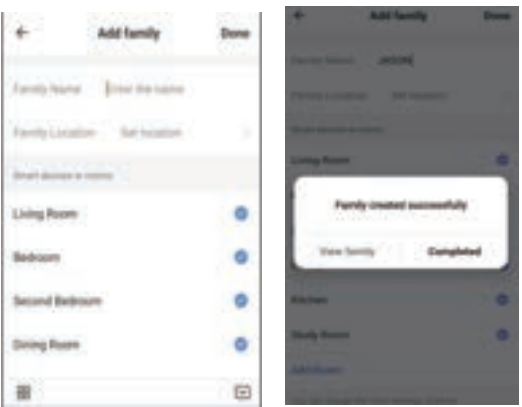

8

6- Smart switch pairing

Turn on mobile phone Bluetooth
Power up the smart switch
Open the APP and tap "Add Device" or "+" at the top right corner.
Pop up window: discover the devices to be added.
Option to select: add / do not add or select (BLE) to add.

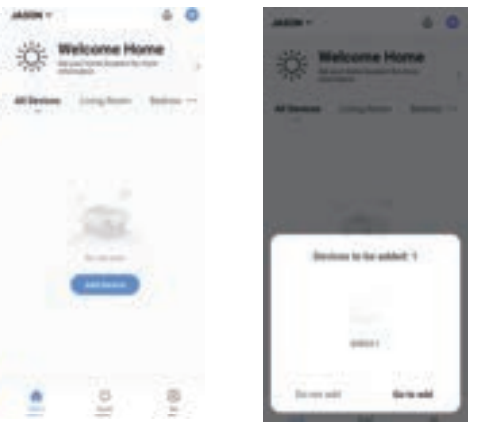

9

Select "+" and enter WIFI password

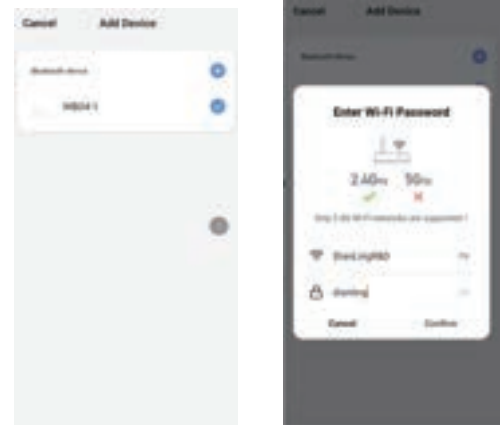

10

Waiting for connection, indication upon successful connection.

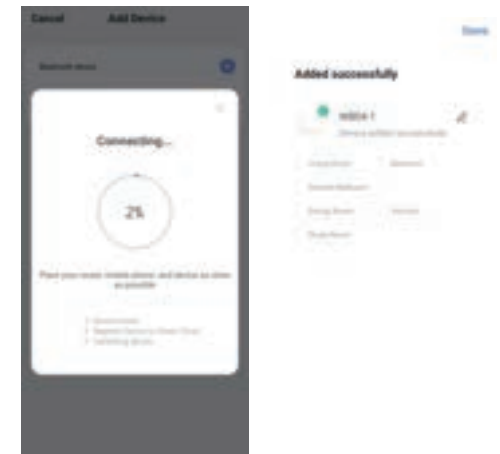

11

SMART TECH
by earth & marver

smart-tech.com.sg
sales@smart-tech.com.sg
support@smart-tech.com.sg



Like us on facebook
@sgSmartTech



Follow us on Instagram
@smarttech_sg

12